

DC..1MHz precision RMS voltmeter

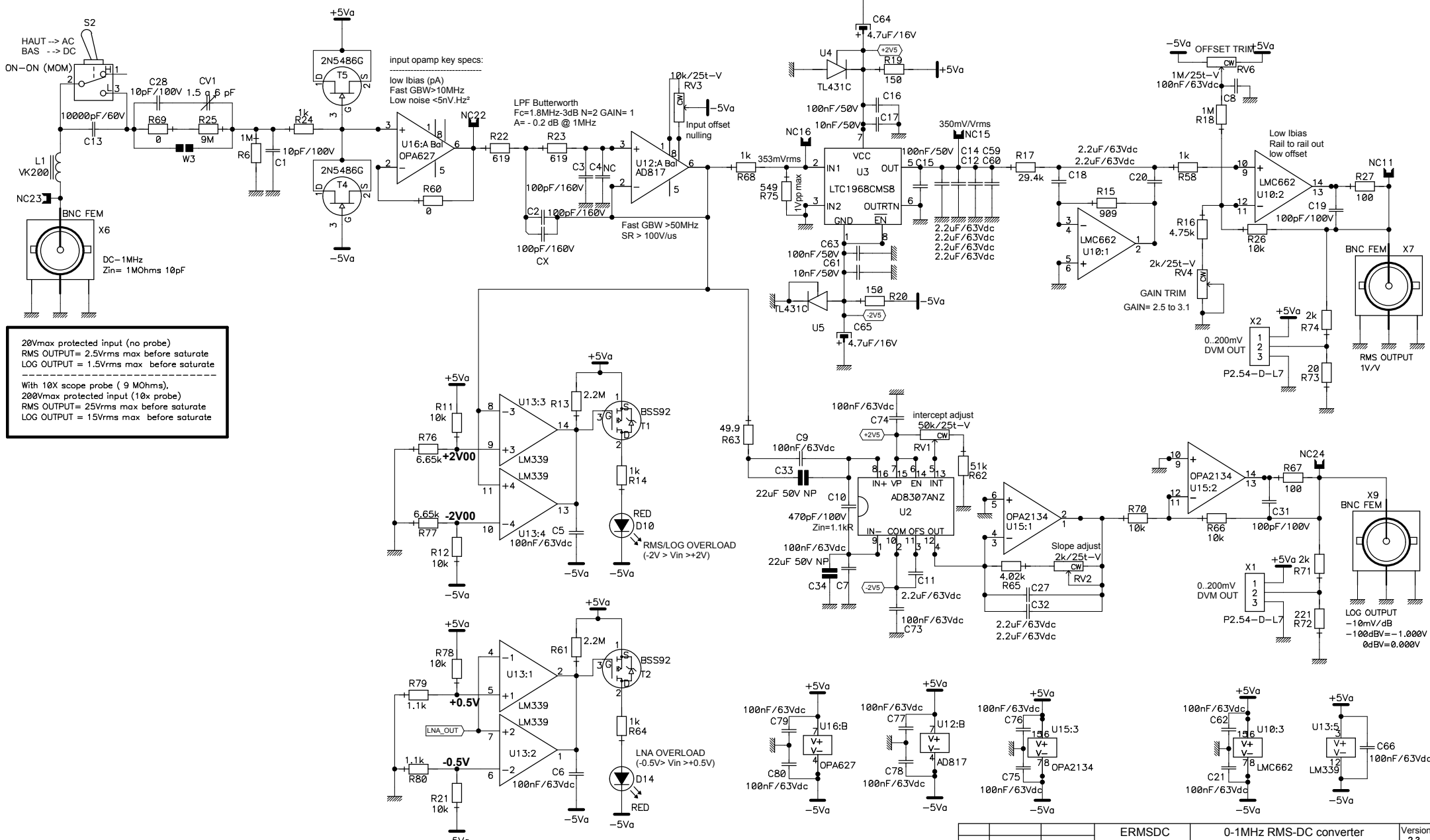

ERMSDC			0-1MHz RMS-DC converter & ultra low noise 1Hz-100kHz 80dB amplifier		Version 2.3
			Sheet1		Page 1 / 2
			Sat Feb 19, 2011		
2.3	16/02/2011	ON	e-mail: contact@oneaudio.net www.oneaudio.net		
Ver	Date	Nom			

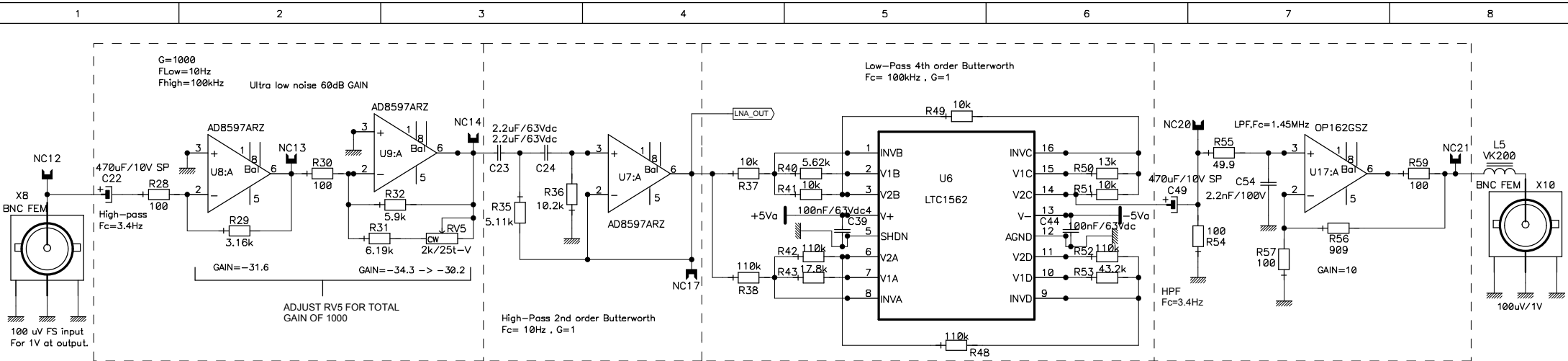

Ultra-low noise 80dB GAIN BLOCK 10Hz..100kHz banpass.

Spare Gate Table		
Last Used	Not Used	Spare Gates
C80	C67, C68	
CV1		
CX		
D14	D1, D2, D4, D5, D12, D13	
L5	L2	
NC24	NC1, NC2, NC3, NC4, NC5, NC6, NC7, NC8, NC9, NC10	
R80	R1, R2, R3, R4, R5, R7, R8, R9, R10	
RV6		
S2	S1	
T5	T3	
U19	U11, U14, U18	
W3		
X20	X3, X4, X5, X11, X12	

Power Table							
Ref Des	Device(Type)	Package	GND	+2V5	-5VA	+5VA	-2V5
U1	LM337IMP	SOT223			3		
U2	AD8307ANZ	DIP8_SOICB_A		15,14,7,6		10,2	
U3	LTC1968CMS8	DIP8N_MSOP8		11,3,14,6	7,15		16,8,1,9
U4	TL431C	TO92		2	1,3		
U5	TL431C	TO92		1,3			2
U6	LTC1562	DIP16_SSOP20		12,5,31,22	13,33,30,32,23,20	21,4	
U7	OPA134	DIP8_SOICB_A			4,12	7,15	
U8	AD8597ARZ	DIP8_SOICB_A		11,3	4,12	7,15	
U9	AD8597ARZ	DIP8_SOICB_A		11,3	4,12	7,15	
U10	LMC662	DIP8_SOICB		6,5	8,7	16,15	
U12	ADB17	DIP8_SOICB_A			4,12	7,15	
U13	LM339	DIP14_N			12	3	
U15	OPA2134	DIP8_SOICB		5,6,9,10	7,8	15,16	
U16	OPA627	DIP8_SOICB_A			4,12	7,15	
U17	OP162GSZ	DIP8_SOICB_A			4,12	7,15	
U19	LM317MDCY	SOT223				4,2	

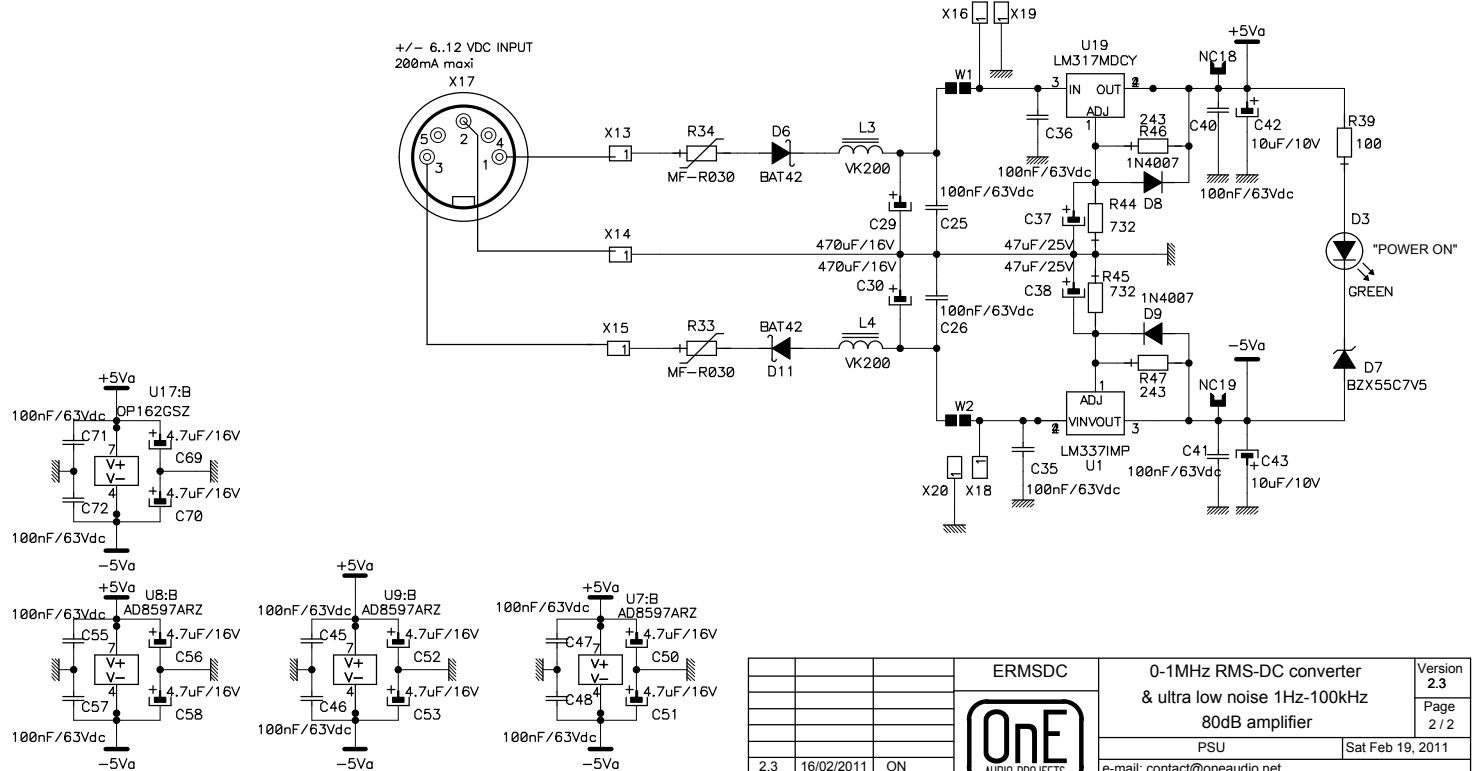

ERMSDC			0-1MHz RMS-DC converter & ultra low noise 1Hz-100kHz 80dB amplifier		Version 2.3
			PSU		Page 2 / 2
			Sat Feb 19, 2011		
			e-mail: contact@oneaudio.net www.oneaudio.net		
2.3	16/02/2011	ON			
Ver	Date	Nom			