

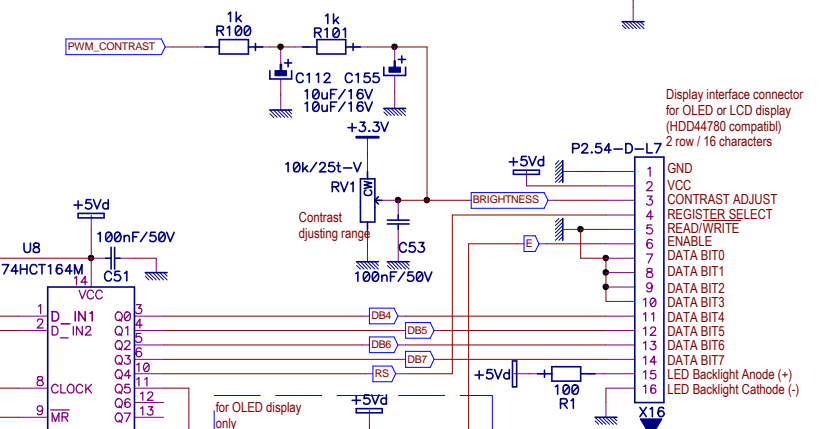

Hardware configuration of WM8804 for master mode SPDIF Rx input and 24bits I2S format.

Hardware mode (page 18)	Master mode (page 18)	TXSRC SPDIF Rx (p19)	Audio format I2S 24 bits (Table 16, p19)
0	1	0	1
SDIN(3)	SCLK(1)	CSB(5)	SDOUT(4)
			GP00(2)

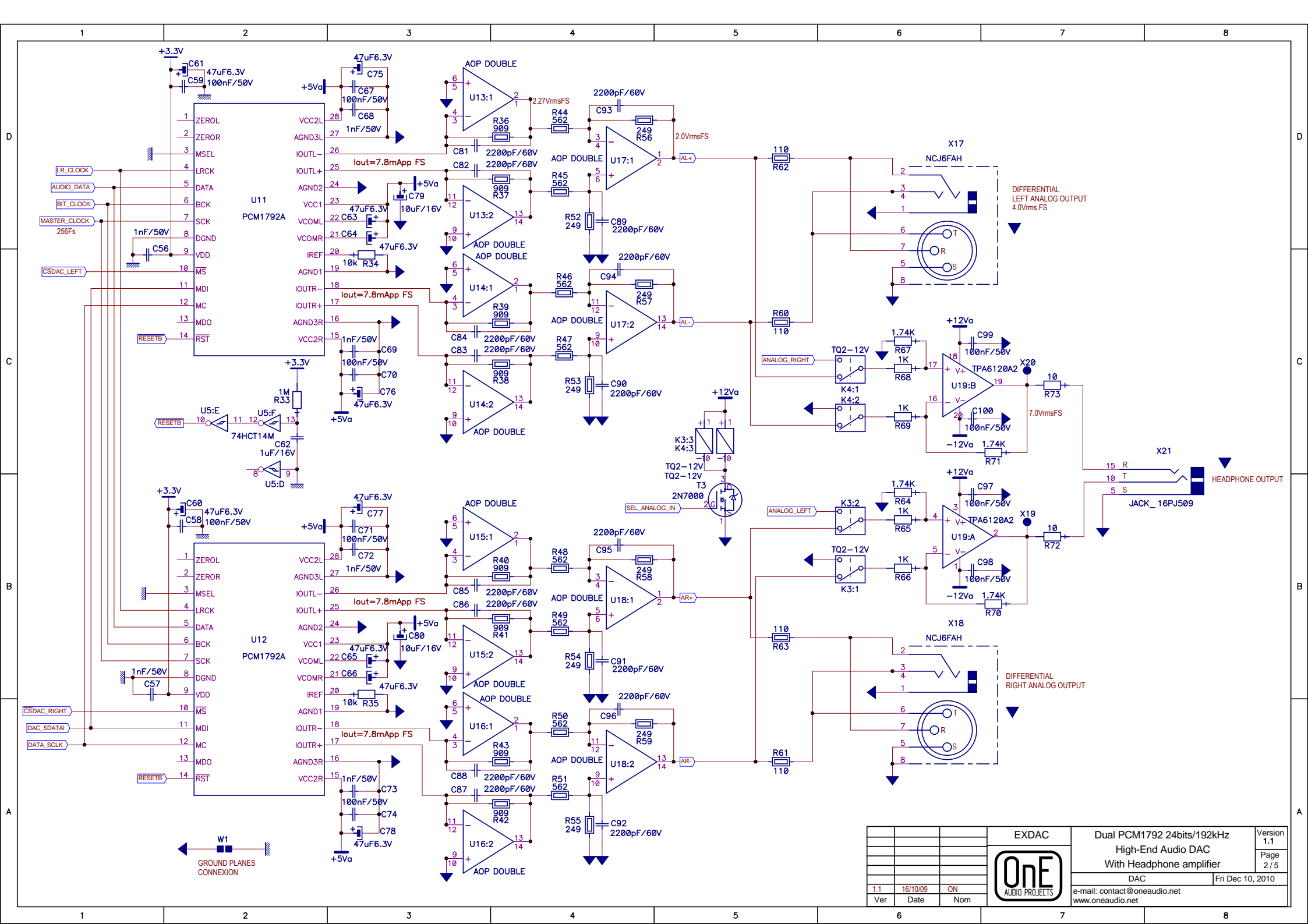

EXDAC				Dual PCM1792 24bits/192kHz High-End Audio DAC With Headphone amplifier	Version 1.1
1.1	16/10/09	ON			Page 1 / 5
Ver Date Nom			DIR		Fri Dec 10, 2010
			e-mail: contact@oneaudio.net		www.oneaudio.net



EXDAC			Dual PCM1792 24bits/192kHz High-End Audio DAC With Headphone amplifier		Version 1.1
			DAC		Page 2 / 5
1.1			16/10/09		ON
Ver			Date		Nom
			Fri Dec 10, 2010		
			e-mail: contact@oneaudio.net		
			www.oneaudio.net		

		Power Table																					
Ref Des	Device(Type)	Package	+5VA	-12VA	+12VA	NET00051	+3.3V	+3.3VA	GND_M	NET00082	NET00130	NET00131	NET00132	NET00133	NET00136	VDDI	+5VD	NET00008	NET00162	NET00033	NET00040	GND	NET00061
U1	LT1763CS8	SOIC8_N			5,8				3,6,7									1					
U2	LT1763CS8	SOIC8_N							3,6,7									5,8					
U4	GP1FAV31RK0F	GP1FA					1		2														
U5	74HCT14M	SOIC14_N					14		9,7														
U6	PCM2906	SSOP_28_N							12,26,11,13,18,22,24,4	23	19	17	14	10	27,8,9	3							
U7	WM8804GEDS	SSOP_20_N					19	7	18,8														
U8	74HCT164M	SOIC14_N							7								2,9,14						
U9	PIC16LF87-I/SO	SOIC18_L					14		5														
U10	TSOP232236	TSOP322_IR							3	2													
U11	PCM1792A	SSOP_28_N	23,15,28				9		8,3,27,24,19,16														
U12	PCM1792A	SSOP_28_N	23,28,15				9		8,3,27,19,16,24														
U13	AOPDOUBLE	DIP8_SOIC8		8,7	16,15				6,5,10,9														
U14	AOPDOUBLE	DIP8_SOIC8		8,7	16,15				10,9,6,5														
U15	AOPDOUBLE	DIP8_SOIC8		8,7	16,15				10,9,6,5														
U16	AOPDOUBLE	DIP8_SOIC8		8,7	16,15				6,5,10,9														
U17	AOPDOUBLE	DIP8_SOIC8		8,7	16,15																		
U18	AOPDOUBLE	DIP8_SOIC8		8,7	16,15																		
U19	TPA6120A2	SOIC20_L_PWP	20,1	18,3					21														
U20	LM317MDCY	SOT223			3												4,2						
U21	LM7805CT	TO220			3				2,4														
U22	AOPDOUBLE	DIP8_SOIC8		8,7	16,15																		
U23	LM1117MP-3.3	SOT223							1								3						
U24	LM1117MP-3.3	SOT223			3				1														
U25	AOPDOUBLE	DIP8_SOIC8		8,7	16,15																		
U28	LM2940CT-12	TO220																	3				2,4
U29	LM2940CT-12	TO220																4,2			3		
U30	74VHC1GT125	SOT23_5L														5							1,3

Spare Gate Table		
Last Used	Not Used	Spare Gates
AFF1		
C161		
D19		
K4		
L5		
M2		
Q1		
R104		
RAD3		
RV1		
S1		
SUP_F1		
T3		
TR4		
U30	U26, U27	
VR1		
W5		
X28	X3, X4, X5	

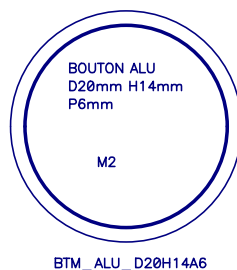
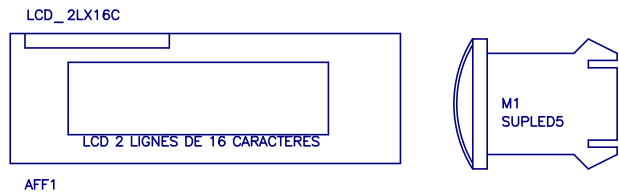

			EXDAC		Dual PCM1792 24bits/192kHz High-End Audio DAC With Headphone amplifier		Version 1.1
					POPO		Page 3 / 5
					Fri Dec 10, 2010		e-mail: contact@oneaudio.net www.oneaudio.net
1.1	16/10/09	ON					
Ver	Date	Nom					

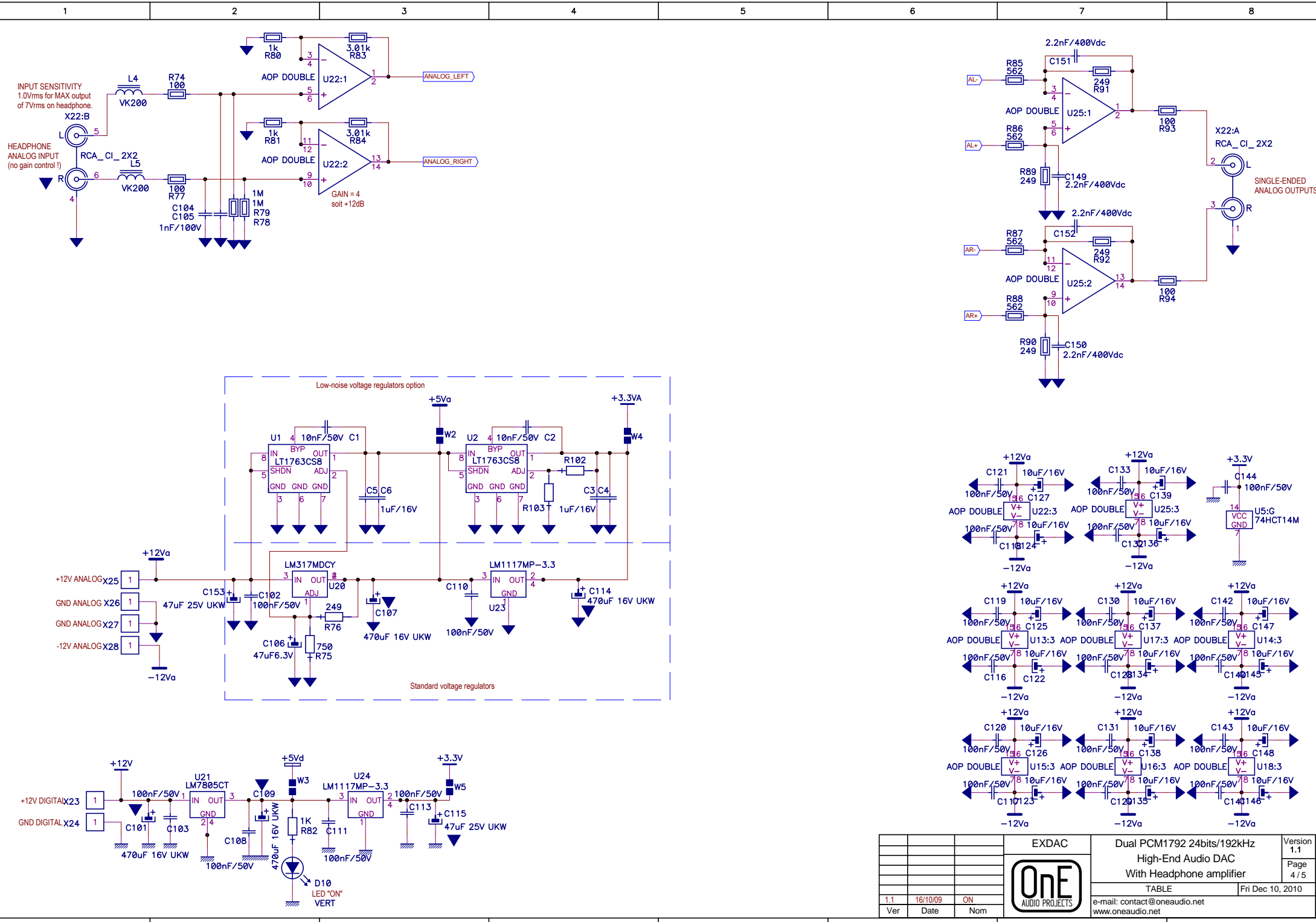

			EXDAC	Dual PCM1792 24bits/192kHz	Version 1.1
				High-End Audio DAC	Page 4 / 5
				With Headphone amplifier	
			TABLE	Fri Dec 10, 2010	
1.1	16/10/09	ON			
Ver	Date	Nom			
			e-mail: contact@oneaudio.net www.oneaudio.net		

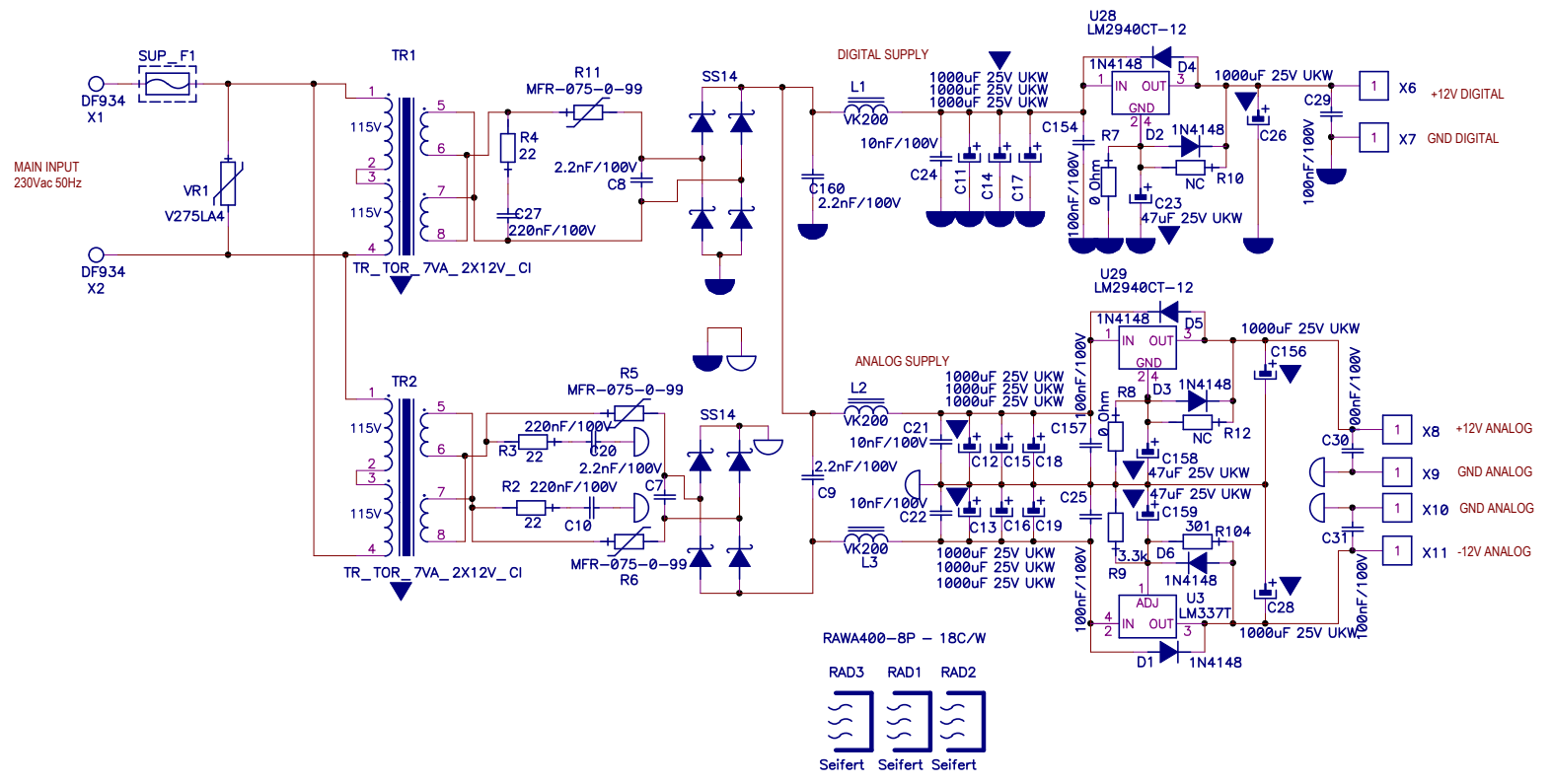

			EXDAC	Dual PCM1792 24bits/192kHz High-End Audio DAC With Headphone amplifier	Version 1.1
				PSU	Page 5 / 5
				Fri Dec 10, 2010	
1.1	16/10/09	ON	e-mail: contact@oneaudio.net www.oneaudio.net		
Ver	Date	Nom			